

# SPECIFICATIONS

## Pump Kit on S 58 SX / S 61 SX

|  | 2525H-6 120/85 MPS |        |
|--|--------------------|--------|
|  | U.S.               | Metric |
| Theor. Concrete Output Per Hour (cubic yards - cubic meters) | 213                | 163    |
| Maximum Pressure on Concrete (psi - bar)                     | 1169               | 80     |
| Maximum Strokes Per Minute                                   | 22                 |        |
| Material Cylinder Diameter (in. - mm)                        | 10                 | 254    |
| Material Cylinder Stroke Length (in. - mm)                   | 98                 | 2500   |
| Differential Cylinder Diameter (in. - mm)                    | 4.7                | 120    |
| Maximum Aggregate Size (in. - mm)                            | 2.5                | 63.5   |

## Boom Specifications

### S 58 SX / S 61 SX

|                                    | U.S.          | Metric      |
|------------------------------------|---------------|-------------|
| Pipeline Diameter (in. - mm)       | 5 / 4.5       | 125 / 112   |
| Vertical Reach (ft.-in. - m)       | 187-9 / 197-1 | 57.2 / 60.1 |
| Horizontal Reach (ft.-in. - m)     | 175-2 / 184-6 | 53.4 / 56.1 |
| Net Horizontal Reach (ft.-in. - m) | 162-6 / 171-9 | 49.5 / 52.3 |
| Unfolding Height (ft.-in. - m)     | 56-5 / 59-8   | 17.2 / 18.2 |
| Section Lengths                    |               |             |
| First Section (ft.-in. - m)        | 34 / 34       | 10.4 / 10.4 |
| Second Section (ft.-in. - m)       | 49 / 49       | 15 / 15     |
| Third Section (ft.-in. - m)        | 47-3 / 50-8   | 14.4 / 15.4 |
| Tip Section (ft.-in. - m)          | 44-10 / 50-8  | 13.6 / 15.4 |
| Slewing Range (degrees)            | 380° / 380°   |             |
| End hose length (ft. - m)          | 12 / 10       | 3.6 / 3     |

Specifications are subject to change without prior notice.

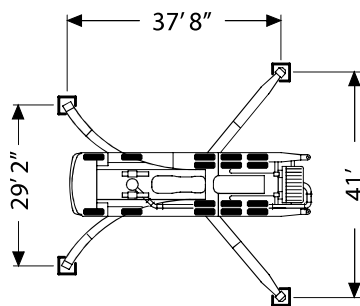

## EASy One Sided Outrigging System

